



## OVAL GEAR

Large capacity positive displacement flowmeter

---

---

### INSTRUCTION MANUAL

---

---

*Models : OM080, OM80H, OM100*



Distributed by:

---

**FLOMEC Factory**  
1 / 19 Northumberland Road,  
Caringbah NSW 2229, Sydney  
AUSTRALIA  
tel : +61 2 9540 4433  
fax : +61 2 9525 9411  
email : [sales@flomec.com.au](mailto:sales@flomec.com.au)  
website : [www.flomec.com.au](http://www.flomec.com.au)

---

IMOMLAR-0907



<b>1.0 General</b>		<b>Page</b>
1.1	Overview	2
1.2	Operating principal	2
1.3	Model Number Information	3
1.4	Specifications	4
<b>2.0 Installation</b>		
2.1	Mechanical Installation	5
2.1.1	Orientation	5
2.1.2	Flow Conditioning & Locations	6
2.2	Electrical Installation	6
2.2.1	Instrument Cable	6
2.2.2	Hazardous area wiring	7
2.3	Pulse Output Selection for pulse meters	7
2.3.1	Hall Sensor Pulse Output	7
2.3.2	Reed Switch Pulse Output	7
2.3.3	Quadrature pulse output	8
2.3.4	Signal integrity verification	8
2.3.5	Bi-directional flow	8
2.4	Meters fitted with Integral Instruments	9
2.4.1	Meter Calibration Factor ( <i>K-factor or scale Factor</i> )	9
<b>3.0 Commissioning</b>		10
<b>4.0 Maintenance</b>		10
4.1	Disassembly of pulse meter	11
4.2	Disassembly of meters fitted with an Instrument	11
4.3	Exploded View & Spare Parts	11 & 12
4.4	Inspection & exploded view	13
4.5	Re-assembly of Meter	13
<b>5.0 Fault Finding</b>		14
5.1	Trouble shooting	15

**General**

**1.1 Overview**

The Oval gear meter is a precise positive displacement flowmeter incorporating a pair of oval geared rotors. These meters are capable of measuring the flow of a broad range of clean liquids.

OM large capacity flowmeters are not suited to most water based products or chemicals, they are specifically designed in aluminium for application to fuels, fuel oils & lubricating liquids and those liquids which are compatible with aluminium and roller bearings made of steel.

These meters are available as a blind meter with pulse output capable of interfacing to most monitoring and control instrumentation or the meter can be fitted with or supplied with instruments such as totalisers, rate totalisers or batch controllers. These instruments also have monitoring and control output options including 4-20mA, scaled pulse, flowrate alarms and batch control logic (*preset metering*).

If your flowmeter is fitted or supplied with an instrument please also refer to the relevant instrument instruction manual.

OM flowmeters can be installed within hazardous areas by using the reed switch pulse output in Intrinsically Safe loops or fitting Intrinsically Safe certified Instruments. Please consult the factory for the availability of flameproof models.

**1.2 Operating Principle**

The Oval gear meters are positive displacement flowmeters where the passage of liquid causes two oval geared rotors to rotate within a precision measuring chamber and with each rotation a fixed volume of liquid is displaced passing through the meter. Magnets embedded within the rotors initiate a high resolution pulse train output. The pulse output can be wired directly to process control and monitoring equipment or can be used as an input to instruments supplied with or fitted directly to the meter.

The benefits of this technology allow precise flow measurement and dispensing of most clean liquids irrespective of their conductivity, with other liquid characteristics having nil or minimal effect on meter performance. This metering technology does not require flow profile conditioning as required with alternative flow technologies making the installation relatively compact and low cost.

**OPERATION :**

Liquid travels around the crescent shaped chambers created by the rotational movement of the rotors

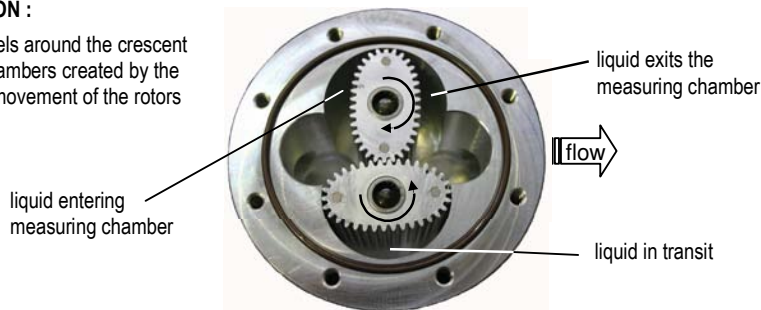

**Model coding**

<b>OM080</b>	80mm ( 3" )
<b>OM80H</b>	80mm ( 3" high flow )
<b>OM100</b>	100mm ( 4" )

**Body material**

<b>A</b>	Aluminum
<b>D</b>	Ductile iron

**Rotor material**

<b>4</b>	Aluminum
----------	----------

**Bearing type**

<b>4</b>	Hardened steel roller bearings
----------	--------------------------------

**O-ring material**

<b>1</b>	Viton ( <i>standard</i> ) -15~+200°C ( -5~+400°F )
<b>2</b>	Ethylene Propylene Rubber -150°C (300°F) <i>max.</i>
<b>3</b>	Teflon encapsulated viton -150°C (300°F) <i>max.</i>
<b>4</b>	Buna-N (Nitrile) -65~+100°C (-53~+212°F)

**Temperature limits**

<b>2</b>	120°C ( 250°F ) - <i>see note 1</i>
<b>5</b>	120°C ( 250°F ) - <i>see note 2</i>

**Process connections**

<b>1</b>	BSP female threaded
<b>2</b>	NPT female threaded
<b>4</b>	ANSI-150 RF flanges
<b>5</b>	ANSI-300 RF flanges
<b>6</b>	PN16 DIN flanges
<b>9</b>	Customer nominated

**Cable entries**

<b>Code O</b> with mechanical register options	<b>0</b>	3~6mm cable gland (B2/B3 options)
	<b>1</b>	M20 x 1.5mm
	<b>2</b>	1/2" NPT

**Model No. Example**

<b>OM080</b>	<b>A</b>	<b>4</b>	<b>4</b>	<b>1</b>	<b>5</b>	<b>1</b>	<b>1</b>	<b>R2</b>
--------------	----------	----------	----------	----------	----------	----------	----------	-----------

**Integral options**

2 NPN open collector phased outputs	<b>QP</b>	Quadrature pulse output
IECEX & ATEX approved	<b>E1</b>	Explosion proof ~ Exd
IECEX & ATEX approved	<b>Q1</b>	Exd with Quadrature pulse
accum. & reset totals, pulse output	<b>B2</b>	BT11 dual totaliser
IECEX & ATEX approved	<b>B3</b>	Intrinsically safe BT11 (I.S.)
flow rate, totals & all outputs	<b>R2</b>	RT12 Flow Rate Totaliser
IECEX & ATEX approved	<b>R3</b>	Intrinsically safe RT12 (I.S.)
dc 2 stage batch controller	<b>E0</b>	EB10 batch controller
<b>M*</b> = M1 litres, M2 gallons	<b>M*</b>	3 digit mechanical reset totaliser
<b>M*</b> = M3 litres, M4 gallons	<b>M*</b>	4 digit mechanical reset totaliser
consult factory	<b>SB</b>	Specific build requirement

(1) 120°C (250°F) rating of the pulse meter, 80°C (180°F) rating with BT, RT & EB options.

See temperature code 5 for higher temperature with BT, RT, & EB

(2) Cooling fin is fitted with integral instruments for operation between 80~120°C (180~250°F)

**Specifications**

Model prefix :	OM080	OM80H	OM100
Nominal size ( inches )	80mm ( 3" )	80mm ( 3" )	100mm ( 4" )
* Flowrange ( litres / min )	35 ~750	50 ~1000	75 ~1500
* Flowrange ( USGM )	10 ~200	13 ~260	20 ~400
Accuracy @ 3cp	±0.2% of reading ( 15:1 turndown) ±0.5% for 20:1		
Repeatability	typically ±0.03%		
Temperature range	-20°C ~ +120°C ( -4°F ~ +250°F )		
Maximum pressure ( threaded meters )	bar ( PSI )		
aluminium	12 ( 180 )	12 ( 180 )	10 ( 150 )
Ductile iron	12 ( 180 )	12 ( 180 )	10 ( 150 )
Protection class	IP66/67 (NEMA4X), optional Exd IIB T6 or I.S.		
Recommended filtering	350 microns ( 40 mesh ) minimum		
<b>Electrical</b> - for pulse meters ( see also optional outputs )			
Output pulse resolution :	pulses / litre ( pulses / US gallon ) - nominal		
Reed switch	2.32 ( 8.8 )	1.55 ( 5.87 )	1.1 ( 4.15 )
Hall effect	9.3 ( 35.2 )	6.2 ( 23.5 )	4.4 ( 16.6 )
Quadrature Hall option	4.65 ( 17.6 )	3.1 ( 11.8 )	2.2 ( 8.3 )
Reed switch output	30Vdc x 200mA max. (max. temp. shock 10°C (50°F) / min)		
Hall effect output (NPN)	3 wire open collector, 5 ~24Vdc max., 20mA max.		
<b>Optional functions</b>			
Display	flowrate, total (accumulative & resettable)		
Preset batching	1 & 2 stage high speed batch control		
<b>Optional mechanical registers ( IP65 )</b>			
3 digit reset totaliser	9999 litres or gallons ( 6 digit accumulative )		
4 digit reset totaliser	99999 litres or gallons ( 8 digit accumulative )		
<b>Optional outputs</b>			
Flow	4 ~ 20mA, high & low flow rate alarms		
Pulse	scaled pulse (programmable), pulse amplifier		

\* Maximum flow on fuels may be maintained for intermittent periods of refuelling.  
 \* Max. flow is to be reduced as viscosity increases, max. press. drop 100Kpa (15psi)

**2.0 Installation**

**2.1 Mechanical Installation** Prior to installing the meter check :

# The fluid is compatible with the meter materials of construction using appropriate information such as fluid compatibility charts and site experience.

# Application and process conditions are compatible with the meter specifications. Minimum and max. flows are within the meter specified range including any in-situ cleaning processes. When metering viscous liquids the maximum allowable flow may need to be reduced to ensure the pressure drop across the meter does not exceed 100 kPa (1 Barg, 15 PSIG).

# Process temperature and pressure does not exceed meter ratings.

# The meter is not exposed to process temperatures and pressures that will cause the liquid medium to gasify (flash) within the meter.

**2.1.1 Orientation**

The flowmeter MUST be mounted so that the rotor shafts are in a horizontal plane. This is achieved by mounting the meter so that the terminal cover or integral instrument display, whichever is fitted, is facing in a horizontal direction. Note the terminal cover or instrument display can be rotated in 90 degree increments to provide access to the electrical entry and to allow the display orientation to suit the installation.



When installed incorrectly the weight of the rotors will bear down on the base of the measuring chamber.

The meter will operate in the alternative orientation, however, it is likely its life & performance will be reduced as a result of the gravity pull on the rotors.

Liquid can flow into the meter from either a horizontal or vertical direction. For vertical flow installations the most common orientation is for the liquid to rise through the meter (i.e. travel from bottom to top) to assist in air or entrained gas elimination. The meter operation is independent of the liquid flow direction thus there is no markings for inlet or outlet.

### 2.1.2 Flow Conditioning and Locations

**Strainer:** It is recommended to INSTALL a 80mesh (200 micron) strainer immediately upstream of (prior to) the meter. Strainers are available from the factory.

**Flow conditioning:** The flowmeter does not require any flow conditioning, therefore straight pipe runs before or after the meter are not required. If required, the pipe size about the meter can be altered to suit the installation.

**Locations:** The flowmeter is preferred to be fitted upstream of any flow control and/or shut off valve, this prevents free discharge from the meter and minimizes the risk of drainage and air entrapment which can result in erroneous readings or damage the meter on start up.

Process or safety critical meters should be installed in a by-pass section of pipe with isolation valves to enable the meter to be isolated and serviced as required. A by-pass installation also allows purging of the system during commissioning (see *Commissioning*). The meter must be appropriately rated and is typically located downstream (on the discharge side) of the pump.

If mounted outdoors ensure a suitable watertight gland or plug is used to seal any open electrical entries. In humid environments take precautions to avoid condensation build up within the electrical and/or instrument enclosure. It is good wiring practice for conduits to be connected from the bottom of an entry port, in this way condensation will gravitate away from any terminal housing.

**Fluid state:** Fluid entering the meter must remain a liquid at all times so protect the meter to avoid solidification or gelling of the metered medium. If meters are to be trace heated or jacketed in any way the maximum temperature rating of the meter must not be exceeded. Size the meter to avoid gasification of volatiles (*flashing*) within the liquid due to the pressure drop experienced within the system or within the meter.

**Hydraulic shock:** If pressure surges or hydraulic shock of any kind is possible, the system upstream of the meter must be fitted with a surge suppressor or pressure relief valve to protect the meter from damage. High frequency flow pulsations can damage the meter. Such pulsations can be caused by the injection profile in diesel engines. Most pulsations are removed with the installation of a suitable pulsation dampener.

## 2.2 Electrical Installation

**2.2.1 Instrument Cable** Twisted pair low capacitance shielded instrument cable 7 x 0.3mm (0.5mm<sup>2</sup>) should be used for electrical connection between the flowmeter and remote instrumentation. The cable screen should be earthed at the readout instrument only to protect the transmitted signal from mutual inductive interference.

The cable should not be run in a common conduit or parallel with power and high inductive load carrying cables as power surges may induce erroneous noise transients onto the transmitted pulse signal or cause damage to the electronics. Run the cable in separate conduit or with other low energy instrument cables. The maximum transmission distance is typically 1000m (3300 Ft).

**2.2.2 Hazardous area wiring** Intrinsically safe wiring including using the reed switch pulse output as simple apparatus, wiring to an Intrinsically Safe Instrument or wiring to the Exd explosionproof option( Exd IIB T4/T6 ) wiring techniques must be undertaken in accordance with the rules, regulations and requirements applying to the territory in which the meter is being installed. The meters should only be connected by qualified staff, the qualified staff must have knowledge of protection classes, regulations & provisions for the apparatus in hazardous areas.

If the flowmeter is fitted with an intrinsically safe instrument refer to the appropriate manual & I.S. supplement for wiring of the instrument inputs and outputs.

Use a separate earth within the cable making sure that the earth conductor does not come in contact with the cable shield / screen. Use only high temperature cable at the flowmeter when the process temperature exceeds 85°C.

**2.3 Pulse Output selection for pulse meters** Two types of output are available on each meter, open collector from Hall Effect sensors or reed switch contact. Each output type is linearly proportional to volumetric flow and each pulse is representative of an equal volume of liquid.

**2.3.1 Hall Effect Sensor Pulse Output** The Hall Effect Sensor is a solid state 3 wire device providing a NPN open collector output. It requires a dc voltage between 5~24Vdc to operate and is the recommended pulse output for powered installations such as local or remote batching.

The pulse output between signal  $\square$  and -0V is a voltage square wave with the high level being the dc voltage available at the open collector  $\square$  and the low level being -0V.

The receiving instrument must incorporate a pull up resistor ( typically greater than 10K ohms in most instruments ) which ties the open collector to the available dc voltage level when the Hall sensor is not energized. When energized the open collector output  $\square$  is pulled to ground through the emitter (-0V).

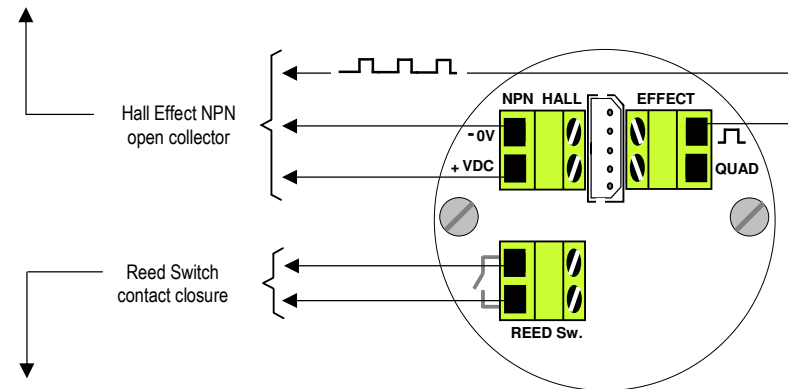

**2.3.2 Reed Switch Pulse Output** The reed switch output is a two wire normally open SPST voltage free contact ideal for installations without power or for use in hazardous area locations when Intrinsically Safe (I.S.) philosophy is adopted. **Note:** when using the reed switch output the liquid temperature must not change at a rate greater than 10°C per minute (50°F per minute). In general the reed switch life will exceed 2 billion actuations when switching less than 5Vdc @10mA as is the case when combined with the RT, EB or BT instruments.

**2.3.3 Quadrature (QUAD) Pulse Output** The diagrams below apply when the meter is fitted with the Quadrature pulse output option (*two Hall Effect sensors arranged to give separate outputs out of phase with one another*).

The Quadrature output is typically suited to custody transfer applications where signal integrity verification is required, it is also used for metering bi-directional flow.

**2.3.4 Signal integrity verification** Many fiscal transactions require the primary measuring device (*flowmeter*) to have Quadrature outputs in order to detect any difference in the number of pulses from each input (*from  $\square$  1 &  $\square$  2*) during delivery.

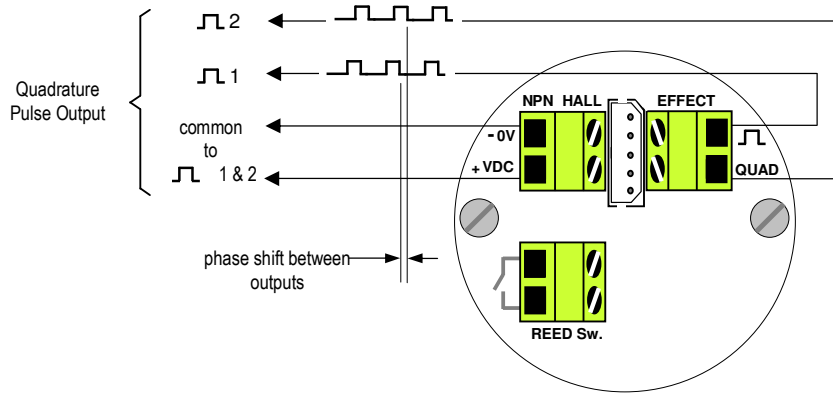

**2.3.5 Bi-directional flow** Combining the Quadrature feature and model PD1 pulse discriminator module produces forward & reverse outputs both of which may be integrated to provide a “net” reading. The RT12 flow rate totaliser will take both output & will perform the “net” flow function.

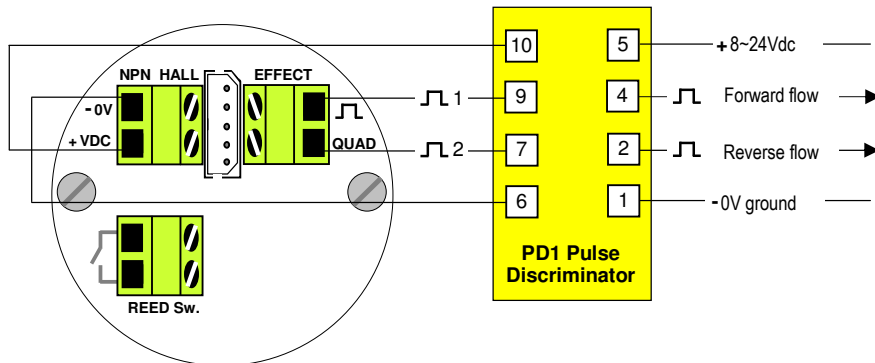

**2.4 Meters fitted with integral Instruments** If your Maxipulse is fitted with an integral instrument such as a totaliser, rate totaliser or batch controller then the pulse output from the meter has been factory wired to the flow input of the readout instrument.



As a default the reed output is pre-wired and DIP switches set for a integral totaliser or rate/totaliser allowing self powered operation of the instrument displays.

Also by default the open collector output from the Hall Sensor is pre-wired and DIP switches set for a integral batch controller allowing high speed, solid state operation of the model EB batch controller.

These defaults may vary at the customer request or for specific applications such as dual flow input or high or low flow so if unsure remove the instrument bezel to check the wiring.

The output(s) and function(s) available from a meter fitted with an integral instrument depends on the model of the instrument fitted and may include meter pulse repeater, prescaled pulse output, 4-20mA flow output, flowrate alarms or single/dual stage batch control logic (*preset controller*).

Refer to the option in the meter model number and relevant instrument manual. Unless programming details were provided at time of order the instrument program will contain factory default parameters. Integral instruments will however be programmed with the relevant calibration factor (*K factor or scale factor*) for the meter.

Factory default settings can be found in the instrument instruction manual and it should be noted all output(s) are turned OFF and if required need to be turned ON then programmed to suit the application requirements.

**2.4.1 Meter Calibration Factor (*K or scale Factor*)** Each flowmeter is individually calibrated and supplied with a calibration certificate showing the number of pulses per unit volume (*eg pulses per litre or pulses per USgallon*). Nominal figures are shown in the specification section of this manual.

Meters fitted with Integral Instruments will have the relevant calibration factor entered into the program of the instrument. Please refer to relevant instrument manual for programming details.

**3.0 Commissioning** Once the meter has been mechanically and electrically installed in accordance with this and any other relevant instrument manual(s) the meter is ready for commissioning.

The meter must NOT be run until the pipework is flushed of foreign matter, more often than not foreign matter is present after pipework fabrication or modification, weld slag, grinding dust, sealing tape & compound &/or surface rust are most common offenders.

Flushing can be undertaken by utilizing a by-pass or removing the meter from the pipework. If neither is practical then the meter rotors must be removed prior to flushing (refer to Maintenance section of this manual for disassembly).

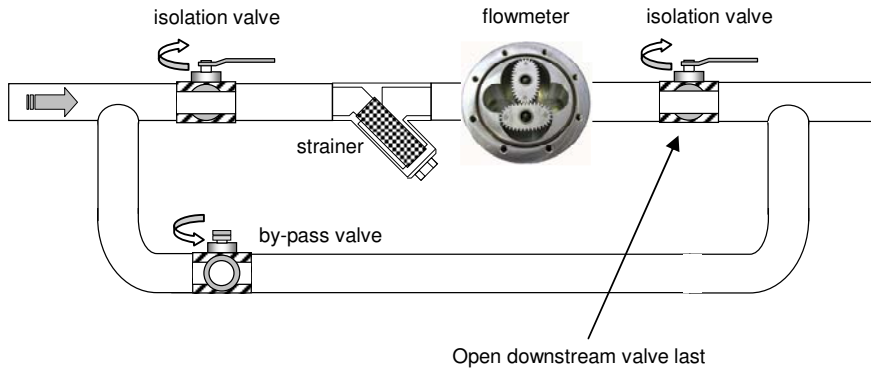

After flushing or following long periods of shutdown the meter must be purged of air/vapour. This can be achieved by allowing the liquid to flow through the meter at a slow rate until all air/vapour is displaced. Never run the meter above its maximum flow or exceed 100kpa (1 bar, 15psi) pressure drop across the meter. Now the meter is ready for its operation to be confirmed by ensuring correct indication or operation at the receiving instrument(s). Refer if necessary to fault finding section of this manual.

**4.0 Maintenance** Adhering to the installation instructions in this manual should ensure your meter provides the required operational performance. Maxipulse are mechanical meters and a periodic maintenance and inspection regime will maximize the operational availability of the meter.

The frequency of maintenance depends on the application factors including liquid lubricity and abrasiveness and operational factors such as flowrate and temperature.

**BEFORE undertaking meter maintenance ensure the following :**

- Associated alarm(s) or control output(s) are isolated so not to affect the process.*
- Voltage supply is isolated from the meter.*
- Liquid supply to the meter is closed off.*
- The meter is depressurized and liquid drained from the meter.*

**4.1 Disassembly of Pulse meter (refer exploded view)** If required to gain access to the meter terminals and pulse output board, undo the 4 cap screws (15), remove the cover (14) carefully to avoid putting strain on the terminal connections. The pulse output board (11) can now be accessed and removed if necessary (screws 12).

If required to gain access to the oval geared rotors under the 8 body screws (10), carefully pry the meter body apart avoiding misplacing or damaging the O-ring (8) and rotors (7).

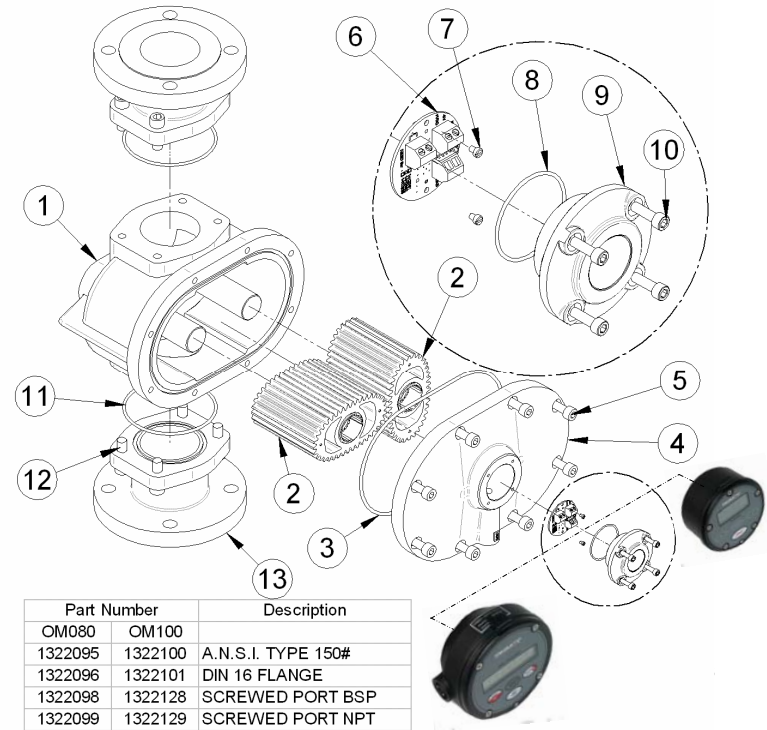

**4.2 Disassembly of meters fitted with an Instrument** If the meter is fitted with an integral instrument the instrument display assembly must be removed if required to gain access to the instrument terminal connections, instrument battery or pulse output board. This is achieved by undoing the bezel screws and separating the display assembly from its base. Do not stress or damage the wires that connect the display assembly to the meter output. Take care not to misplace or damage O-ring(s). The pulse output board can now be accessed. To remove the pulse output board, first undo the screws that fix the instrument base to the flowmeter.

4.3 SPARE PARTS (refer to exploded view)

Item Description	Models		
	OM080A	OM80HA	OM100A
<b>1 Body</b>	Part No.		
body without rotor shafts	1301116	1301067	1301073
<b>1a Rotor shaft</b> shaft O-ring size :	( size BS117 )	( size BS123 )	( size BS123 )
hardened steel	1305083	1305039	1305040
<b>2 Rotor assembly set</b>			
rotors, magnets & bearings	1424116	1424078	1424079
<b>3 Body O-ring</b>	( size BS260 )	( size BS123 )	( size BS123 )
viton - standard (BS153)	13032601	13032671	13032671
teflon (BS153)	13032603	13032673	13032673
<b>4 Meter cap</b>			
with M20 conduit entry	1302136	1302102	1302102
with 1/2" NPT conduit entry	1302152	1302070	1302070
<b>5 Cap screw</b>	( M10 x 30 )	( M10 x 30 )	( M10 x 35 )
M10 x 40mm socket head	130810105	130810105	130810103
<b>6 Pulse output board</b>			
standard pulse board		1412032	1412032
quadrature pulse board		1412037	1412037
<b>7 Output board screw</b>			
M3 x 4mm cheese head		130803101	
<b>8 Terminal cover O-ring</b>			
metal covers (BS132)		13031321	
<b>9 Terminal cover</b>			
aluminum		1306020	
<b>10 Terminal cover screw</b>			
M5 x 16mm socket head		130805101	
<b>11 Flange portion O-ring</b>			
viton - standard (BS123)	13032371	13032371	13032451
teflon (BS123)	13032373	13032373	13032453
<b>12 Flange portion screw</b>			
M12 x 45mm socket head		130812107	
<b>13 Process connections</b>	refer diagram opposite		

**Recommended spares :**

Item 7, rotor assembly set
Item 8, body O-ring
Item 11, pulse output board

4.4 Inspection (refer Exploded View) Inspect O-rings for damage, chemical attack, deformity or any form of deterioration.

Remove, inspect and clean the rotors, also check that the magnets have not been chemically attacked. Check the measuring chamber for damage or scoring & redress if necessary, the rotor shafts should NOT be loose or able to be rotated.

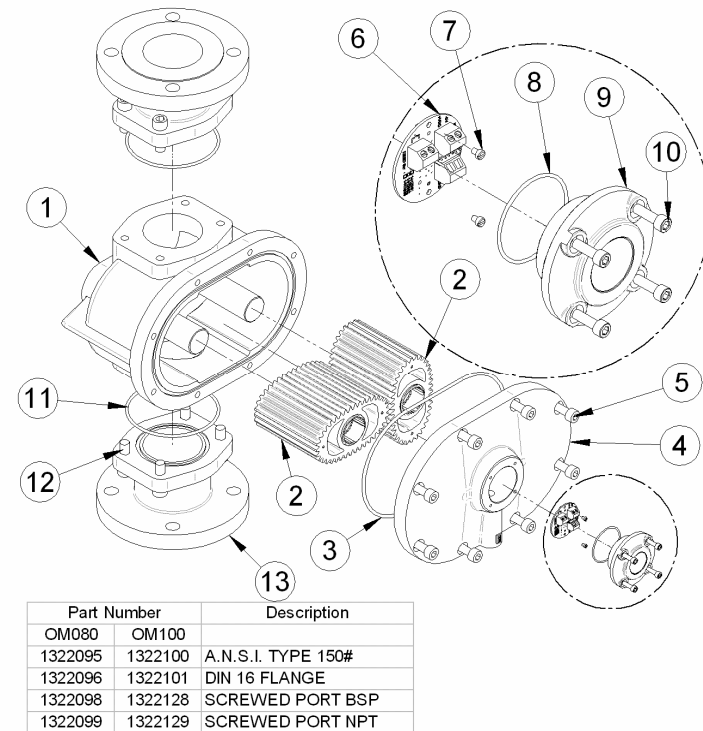

4.5 Re-assembly of meter (refer Exploded View) When re-installing the rotors all four magnets MUST be visible when both rotors are in place. Both rotors will only engage correctly if fitted precisely at an orientation of 90 degrees to each other. Rotate the rotors slowly by hand to ensure they are correctly fitted at the same time check the rotor shafts & rotor bearings for wear.

Fit the O-ring into the groove and assemble the two parts of the meter.

Fit the body cap screws (10) and tighten using a star sequence then torque in the same sequence to 3.5 Nm. This sequence and procedure ensures the meter bodies are assembled correctly and evenly. Fit the pulse output board, terminal cover or instrument as appropriate.

**5.0 Fault Finding** Pulse meters have two distinct sections: the mechanical wetted section housing the rotors and the electrical section housing the pulse output board.

Meters fitted with integral instruments have these two sections plus the instrument. The aim of fault finding is to trace the source of the fault to one of these sections. If a fault is traced to an instrument section, refer to the relevant instruction manual.

Below are basic fault finding steps. Also refer to Trouble Shooting Guide on following page.

**Step 1 - Check application, installation and set up.**

Refer to Mechanical Installation section for installation and application factors that may effect the meter operation including pulsation and air entrainment or incorrect meter selection including incorrect flow rate, temperature and pressure or materials compatibility. Refer to Electrical Installation for correct wiring.

**Step 2 - Check for blockages.**

The most common cause of fault/unsatisfactory meter operation, particularly for new or altered installations, is due to blockage within the system or meter caused by foreign particles such as weld slag, sealing tape or compound, rust, etc.

**Step 3 - Ensure flow is present.**

No flow or lower than normal minimum flow may be attributed to a blocked strainer, jammed or damaged rotors within the flowmeter, malfunctioning pump, closed valves or low liquid level in feeder tank.

**Step 4 - Ensure oval gears within meter are rotating.**

Rotation of the oval gears can be heard by holding a screw driver blade to the meter body and pressing the handle hard against the ear lobe. If necessary test the meter with the flow turned off and turned on to familiarize yourself with the audible rotation signature.

**Step 5 - Ensure pulses are being generated during flowing conditions.**

A multimeter is often not fast enough to distinguish the pulse train from the reed switch or Hall Effect sensor. An oscilloscope will allow you to view the output pulse train. When viewing the Hall effect sensor pulse ensure a pull up resistor is installed between the pulse output and the supply voltage (refer electrical installation).

**Step 6 - Confirm Instrument Operation.**

If an associated instrument is connected to the flowmeter confirm its operation by simulating a pulse input onto the flow input terminals. In most instances a contact closure on the flow input terminals is an adequate simulation.

**5.1 TROUBLE SHOOTING**

Symptom	Possible cause	Solution
Meter readings are high	1. Output signal interference	1. Ground shield of signal cable 2. Re-route cable from high electrical energy sources
	2. Entrained air or gas	1. Remove source of air or gas entrapment 2. Install an upstream air eliminator
	3. Pulsating flow from reciprocating style pump	1. Increase back pressure on pump 2. Install a fast response one way check valve 3. Install a surge arrestor between pump & meter 4. Re-calibrate meter in situ to compensate for pulsations 5. Change pump style to smooth delivery type pump
Meter readings are low	1. Damaged or worn rotors	1. Inspect, repair, clean or replace rotors
	2. Damaged or worn measuring chamber	1. Inspect measuring chamber for damage - repair 2. Check concentricity of rotor shafts within chamber
	3. Output signal interference	1. Ground shield of signal cable 2. Re-route cable from high electrical energy sources 3. Check all electrical terminations & wires for continuity.
No output from meter	1. Rotors fouled	1. Check that rounded teeth are towards base of chamber 2. Check for obstruction due to foreign particles 3. Clean, repair or replace rotors
	2. Meter incorrectly reassembled	1. See instructions for reassembly of meter with particular emphasis on positioning of rotors & magnets
	3. No output from output board	1. Check terminal connections & solder joints 2. Ensure dc voltage is available at Vdc & 0V and receiving instrument is fitted with a pull up resistor 3. Replace output board
Not reading on readout instrument	1. Faulty receiving instrument	1. Check DIP switch settings & program data 2. Check terminal connections & electrical continuity 3. Repair / replace receiving instrument